

Amazing FET Circlotron "Antimatter" Version

©2008 Michael Rothacher

Many DIYers have been troubled by Toshiba's announcement to discontinue some of our favorite parts such as the 2SK170 and the 2SJ74 JFETs and their dual-monolithic equivalents. I can assure you, for the time being, that they're still out there, going for \$1-2 apiece. At the time of this writing, a quick [Google](#) search turned up at least a handful of suppliers. Even so, I've received a few emails expressing concern that the project includes these semi-obsolete parts.

Fortunately, it's also possible to build the amp with N-channel JFETs and P-channel MOSFETs, which opens up the possibility of using replacement parts offered by Linear Systems, in particular, the LSK389 dual-monolithic N-channel JFET. These parts are readily available and can be ordered directly from Linear Systems. I think you'll find their sales department helpful, and happy to accept small orders, so no excuses. They sell for \$7-8 USD apiece in small quantities, which may sound like a lot, but you only need two and they're still cheaper than 12AX7's. I used the "B" grade.

I've been referring to this version of the amp as the "Antimatter" version, and it looks like this:

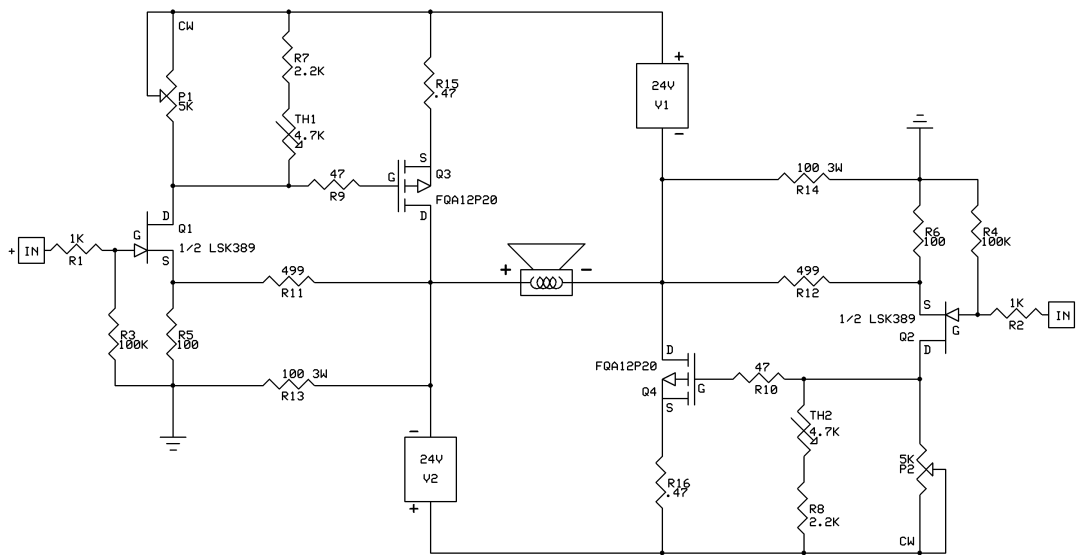

AMAZING FET CIRCLOTRON "ANTIMATTER" VERSION

The PCB's required some changes, so I've made an "Antimatter" CAD file available. I've built and tested a couple of channels and their performance is comparable to the original project. With the LSK's, noise was lower at around 15uV. THD was also lower at very low power levels, and slightly higher elsewhere. The LSK's may also offer an improved reliability factor since they are 40V parts vs. 25V for the 2SJ74's. They are also tightly matched, which is a plus for this project.

Well, there you have it. Now you have options. Happy building.