

L'Amp: Part Deux

by Michael Rothacher

Introduction

In the first L'Amp article, we built-up a simple Class A amplifier using a not-quite unobtainable Static Induction Transistor. It's a nice amp, but it doesn't have a lot of power or voltage gain. In this little vignette, we'll examine a simple option for improvement.

An Inconvenient Truth

Apparently incandescent light bulbs are bad. Wicked, naughty light bulbs.

When I went to the hardware store to pick up bulbs for the first article, there were little signs all over the shelves reading STOCK UP NOW! It seems incandescent bulbs are being phased out in order to save the planet, etc. (not that there's anything wrong with that).

As if audio hobbyists weren't already neurotic enough about obsolete parts, now we have to worry about light bulbs. Of course, we could always use a big power resistor, on a big heat sink, with a big carbon footprint.

Actually, in the US, 300 Watt bulbs are exempt from the current legislation which covers bulbs from 40 to 100 Watts, so we can relax for the time being. However, there is an interesting alternative, if you're so inclined.

L'Amp Gets Inducted

So, maybe you'd like to see a little more gain from our amplifier, and while we're at it, some more power would be nice too. And, whether you use light bulbs or a resistor, the amp isn't terribly efficient (not that there's anything wrong with that) so maybe you'd like to try and improve that figure as well. Oh, and maybe you'd like to accomplish all of that without adding complexity to the circuit or more transistors.

You're very demanding, but okay, we can do that.

Many of the old audio textbooks had amplifier examples which used inductors for the Collector load (Drain for MOSFETs). I inquired about this on the forums many years ago and Nelson Pass responded. He said he'd used a big spool of magnet wire in a Zen-type circuit with good results. A big spool of magnet wire, eh? Again, Pass comes through with a nice hardware store solution. So, I bought a couple of spools and, as happens in this hobby, they went on a shelf and stayed there for several years, until now.

While writing the first L'Amp article I thought the middle part of the 2SK82 curve might be interesting with the right load, so an 11 pound roll of 16 gauge magnet wire came down from its shelf.

What's so special about using an inductor as the Drain load? Well, the impedance of an inductor is frequency dependent. The impedance at a given frequency can be calculated like this:

$$Z_L = 2\pi fL$$

In this formula, f is the frequency in hertz and L is the inductance in henries. We can see that an ideal inductor will have high impedance at high frequency, low impedance at low frequency, and zero resistance at DC.

A big spool of magnet wire isn't exactly an ideal inductor and there will be some DC resistance and other losses. My spool of magnet wire measured around 110 millihenries, and the DC resistance was 5-6 ohms. Lower resistance and more inductance would be nice, but we work with what we have.

You may recall from the first article that the resistance of the two parallel light bulbs was around 13 ohms, and the effective amplifier load was the bulbs in parallel with the 8 ohm speaker, or about 5 ohms. If we replace the bulbs with the spool of magnet wire as in Figure 1, the effective load of the amplifier will be:

$$Load_{eff} = Z_L \parallel R_{Load}$$

Since the impedance of the inductor will be quite high compared to the load at audio frequencies, the effective load is approximately equal to the speaker load, or 8 ohms. An 8 ohm load line would be a bit flatter, and might just do the trick in the middle of the 2SK82 characteristic curve, so we plug in the inductor (Figure 1) and search for the sweet spot.

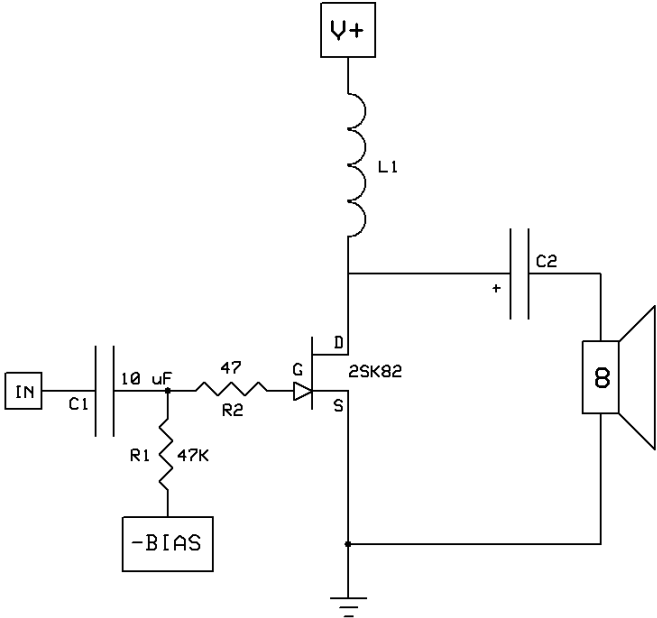

FIGURE 1

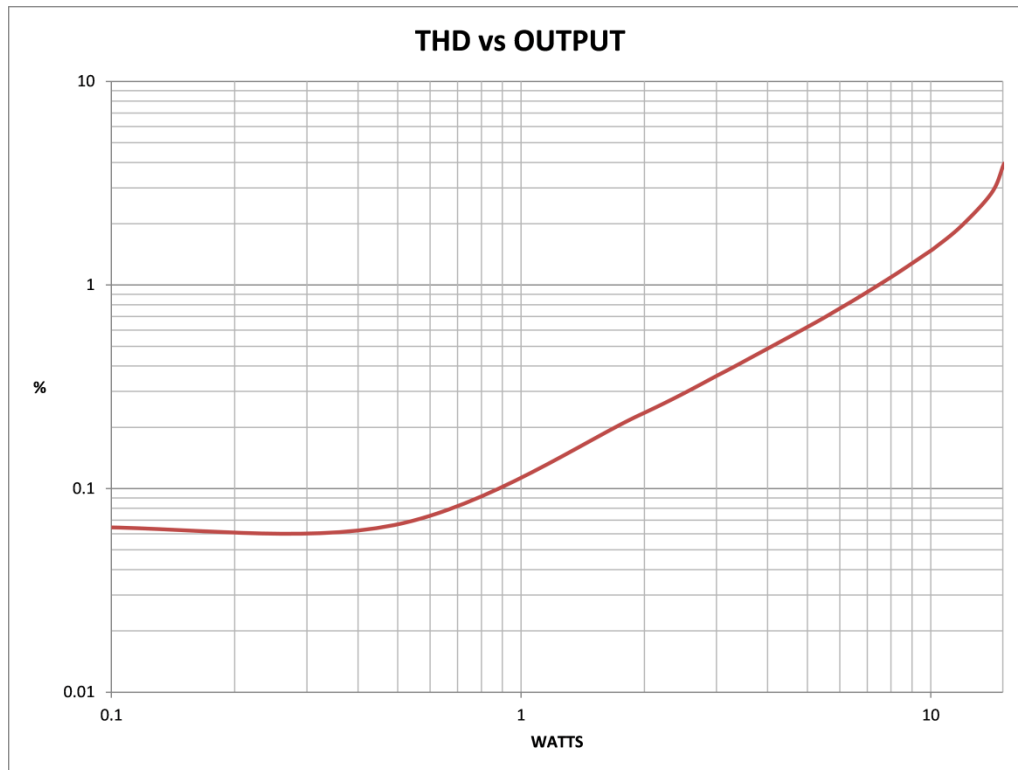

FIGURE 2

Our 1-watt distortion is about the same, but now we're reaching 12 watts with less than 2% distortion (Figure 2).

The inductor stores energy in its magnetic field which effectively increases the supply voltage (double in theory). This increases our maximum voltage swing, and you may have noticed, I lowered the supply voltage to 35 volts. Our efficiency has improved from 4% with light bulbs to around 20%.

The gain has gone from 6 dB to approximately 8 dB, which isn't a lot, but it's about as much as the original 1994 Zen.

How's that for a slice of fried gold!

More Measurements

Figure 3 is the distortion vs. frequency, and the higher distortion at low frequency is evident. A bigger coil would help, but we've seen worse.

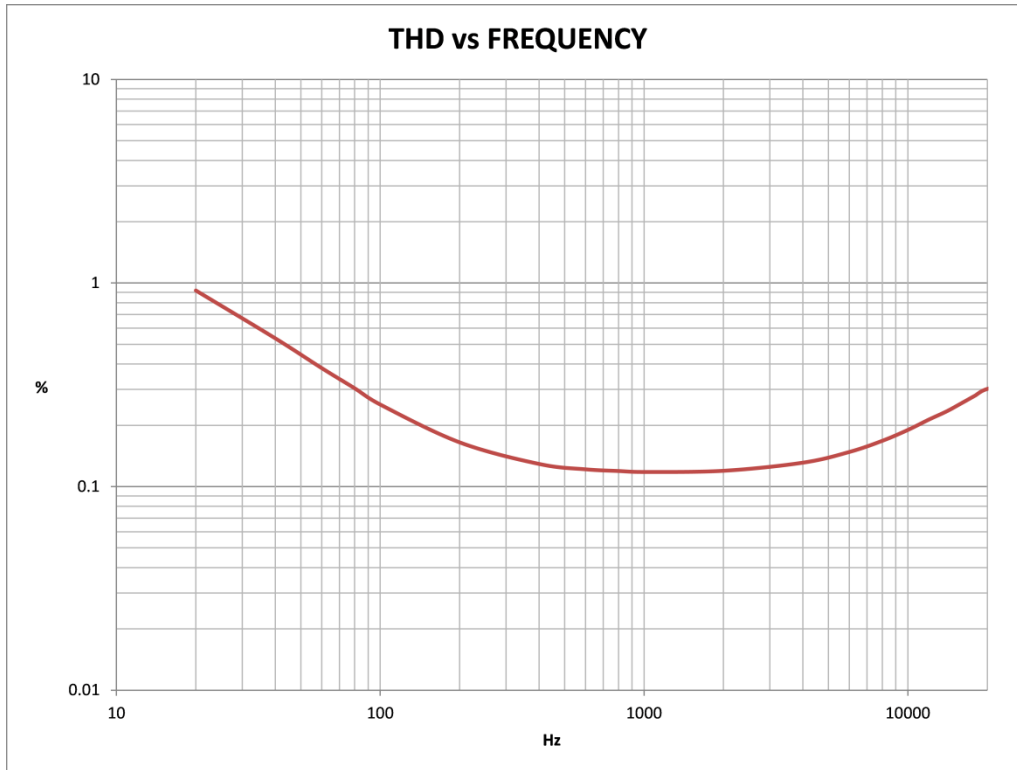

FIGURE 3

The frequency response was -1.12 dB at 20 Hz and -1.72 dB at 60 kHz.

The output impedance was approximately 8 ohms, and the amp didn't have a significant turn-on thump.

Figure 4 is the square wave response at 40 kHz.

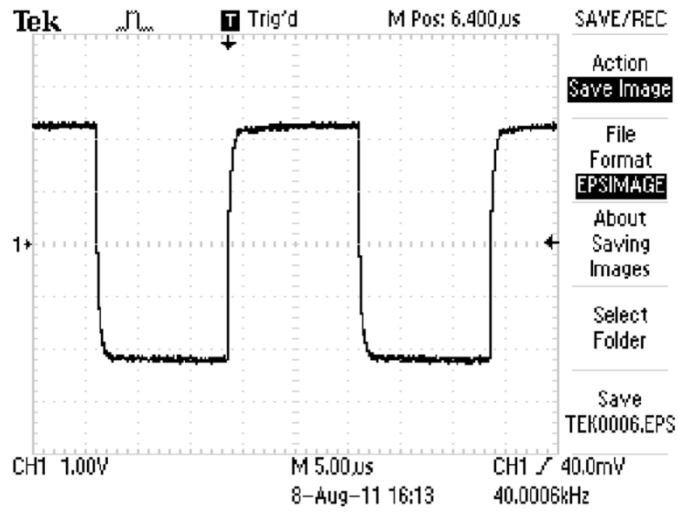
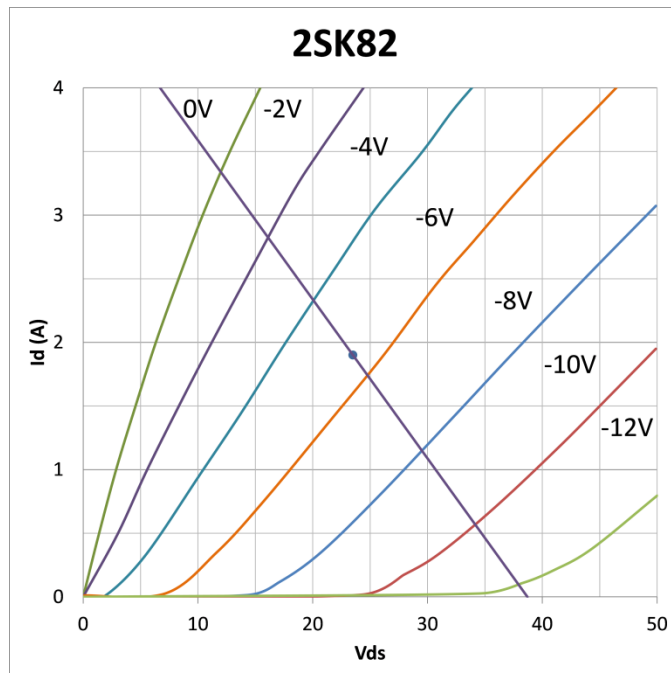

FIGURE 4

For fun, here's the load line:



Heavy Metal

This is a heavy amp, which may appeal to you. Audiophiles like heavy equipment. One of my monoblock channels with transformer, inductor, heat sink, and case, weighs over 25 pounds, giving it an impressive audiophile-approved weight to watts ratio. Each spool of magnet wire will set you back twenty times the cost of a pair of light bulbs, and about half the cost of an output transformer. The magnet wire I used is made by Essex. Each spool is wound with approximately 1,400 feet of heavy-insulation 16 gauge with a resistance of approximately .5 ohms per pound.

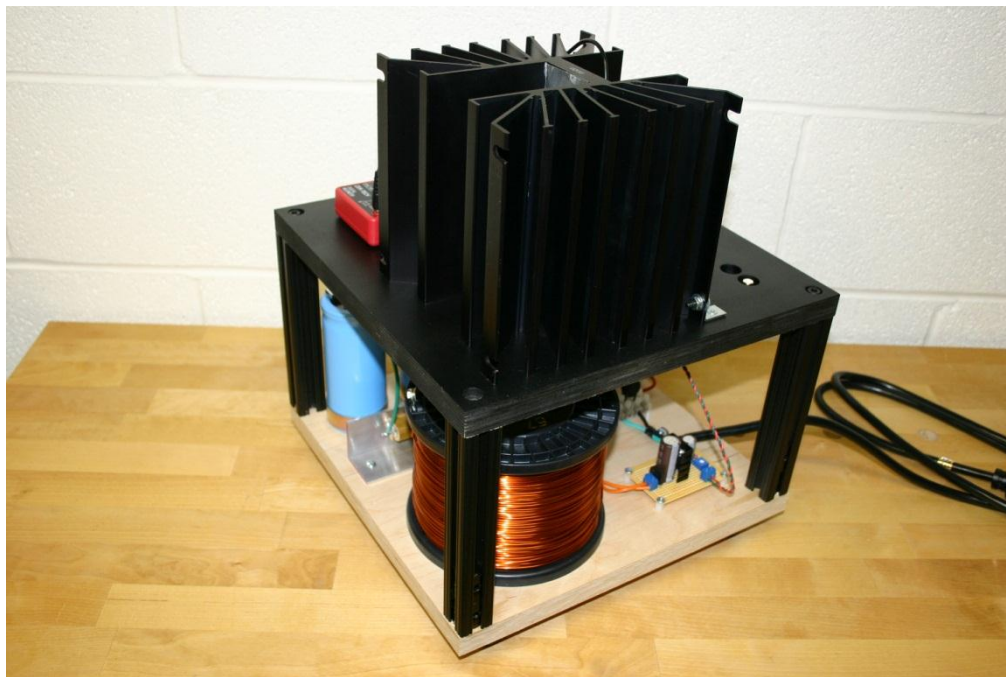

Figure 5 is the complete schematic for a monoblock channel. I used a transformer from Antek with two 28 volt, and two 15 volt secondary windings. The negative bias supply is just a typical application note circuit using an LM7912 negative voltage regulator. You can try something much fancier if you like. P1 adjusts the bias voltage, and R2 sets the minimum bias value.

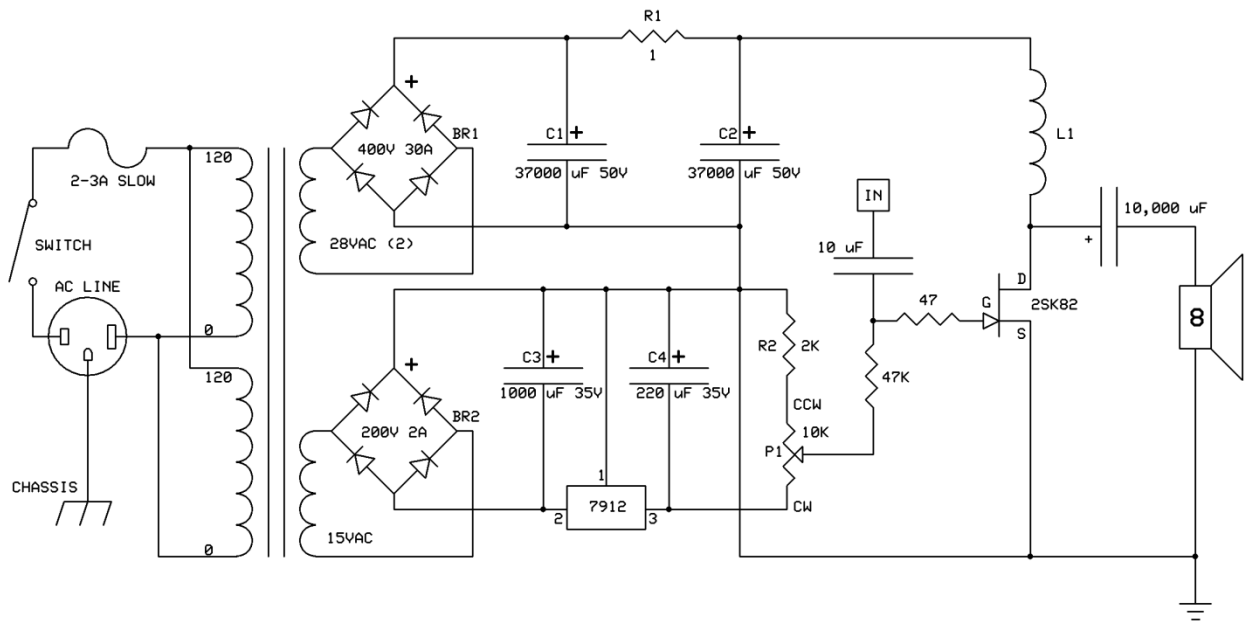

FIGURE 5

Once everything is assembled, test the power supplies first, without the amp connected. If everything checks out, adjust P1 fully clockwise and bring up the power. You should measure approximately -12V from the wiper of P1 to ground. Now, slowly adjust P1 counterclockwise (towards zero volts). You're looking for approximately +23 volts from the JFET drain to ground. The idle current (about 2 amps) is equal to the voltage across the coil divided by its DCR. The bias supply will be around minus 5-6 volts.

If all goes well, you're ready to connect them to speakers and try them out.

So, does this one sound tubey?

There are good tube amps, and there are bad tube amps; so, when we compare transistor amplifiers to tubes, we're making a sweeping generalization about the sound of tubes. But, still, eventually the question will arise. Assuming we're talking about attributes like richness and warmth, good depth, and sweet highs, I found this amp to sound much like the original, but (and I could be psyching myself out here) I'd say this one sounds even tubier. Slightly.

We'll Meet Again, Don't Know Where, Don't Know When...

I think it's fair to keep the name *L'Amp*. The *L* in this case stands for *Inductor*. This little upgrade is a pretty good example of just trying something out and seeing what happens. It may be a little over the top, but this *is* DIY after all, and we're generally undisturbed by extreme measures to achieve incremental improvements. I wouldn't view this as a mandatory update. Rather, it depends on your particular requirements and spirit of bold curiosity.

Well, that's all for this pair of articles; I've had a lot of fun preparing them. It is plain to see that Static Induction Transistors are very interesting devices, and have lots of potential as audio amplifiers. I hope you are inspired to try them.

I think we'll be hearing a lot more about SIT transistors in the not too distant future, as I've read that First Watt has begun releasing amps into the wild for evaluation.

Thanks again, to Nelson Pass and friends at the Pass Labs Forum on www.diyaudio.com.

Now go build something!

© Michael Rothacher 2011